

---

---

# **A/C AIR LAUNCHER™**

## **Operating Instructions**

---

---

**P/N 101050 (120 VAC)**

**P/N 101051 (230 VAC)**

## **Thank you for purchasing this A/C AIR LAUNCHER™**

- **As you will notice from the table of contents, the manual for your new product is quite extensive.**
- **To guarantee perfect and successful work with this machine, please take some time to read the manual carefully.**
- **And finally, we believe you will enjoy years of great effects if you care for and maintain your A/C AIR LAUNCHER™.**

**CITC**

**1420 80<sup>TH</sup> SW #D**

**EVERETT, WA 98203**

**(888) 786-CITC**

**[www.citcfx.com](http://www.citcfx.com)**

# Contents

<b>1. Set of Equipment Supplied</b>	<b>3</b>
<b>2. Accessories and Parts</b>	<b>3</b>
<b>3. Confetti Products</b>	<b>3</b>
<b>4. Description</b>	<b>4</b>
<b>5. Safety Instructions</b>	<b>4</b>
<b>6. Operating the A/C AIR LAUNCHER™</b>	<b>5</b>
<b>6.1 Assembly</b>	
<b>6.2 Loading</b>	
<b>6.3 Optional backpressure cap</b>	
<b>6.4 Pressurizing the tank</b>	
<b>6.5 Firing the A/C Air Launcher™</b>	
<b>6.6 Troubleshooting</b>	
<b>7. Service and Maintenance</b>	<b>7</b>
<b>8. Technical Data</b>	<b>7</b>
<b>9. Limited Warranty Conditions</b>	<b>8</b>

## **1. Set of Equipment Supplied**

- **1 A/C AIR LAUNCHER™ (120VAC: P/N 101050; 230VAC P/N 101051)**
- **Instruction booklet**

## 2. Accessories and Parts

- Spare 2" (5cm) Barrel P/N 350020
- Universal DMX 120 VAC, 15A relay P/N 250041
- Wireless Remote RF 120VAC, 15A 13ch P/N 250010
- Roll of 1.5" (3.8cm) black Masking Tape (P/N 350075)
- One dozen 2" (5cm) Push Caps n' Cups set (P/N 350145)
- Air Compressor (P/N TBA)
- Plug switch (P/N TBA)
- Push-button switch (P/N TBA)
- Corded switch extension (P/N TBA)

## 3. Confetti Products

Also check our catalog or website ([www.citcfx.com](http://www.citcfx.com)) for a complete selection of confetti and streamer products

### CONFETTI - SPEED LOAD

**Confetti stacked in 1" x 18" (2.5cm x 46cm) soft-sleeve. Just slide in then pull sleeve**  
*Multi-color mix or Solid colors in stock. Custom mix by request.*

**Tissue Confetti** - Multicolor or solid colors; primary, jewel, pastel 5/8" x 2 1/4" (1.6cm x 5.7cm)  
(P/N 255501)

**Mylar-Tissue Confetti** - Silver or gold mylar & color tissue 5/8"x 2 1/4" (1.6cm x 5.7cm)  
(P/N 255651)

### STREAMERS - SPEED LOAD

**FlameProof, Biodegradable Tissue Paper & Mylar 1" x 20" (2.5cm x 51cm) soft-sleeve for quick loading of your cannons (slide in then remove sleeve - no packing)**

**Tissue Streamer** - 1/2" x 30' (1.3cm x 9.1m) (P/N 255700)

**Tissue Streamers w/ Tissue Confetti** - Multicolor/Colors with confetti inside 1/2" x 30' (1.3cm x 9.1m) (P/N 255750)

**Mylar Streamers w/ Tissue Streamer**-Silver or Gold mylar & Color tissue or rainbow mylar w/ tissue (P/N 255800)

**Tissue Streamers w/ Mylar Confetti** - Multicolor w/silver/gold confetti or mylar streamers w/tissue confetti (P/N 255825)

### BULK/BAGGED CONFETTI & STREAMERS

**Flame proof tissue only in streamer bulk (not speed loads)**

***Bulk is Fluffed & Mixed - Custom Mix Confetti Colors OK***

**Long-Flying Tissue Confetti** - Primary, Jewel, pastel; solids (P/N 255075)

**White Snow Tissue** - 1" (2.5cm) square falls like snow (P/N 255100)

**Mylar Confetti, mixed w/ tissue confetti** - choice of gold, silver or rainbow w/ variety of colors in tissue. (P/N 255115)

**Mylar** - Gold, silver & rainbow confetti (P/N 255110)

**Tissue Streamers** - Pick-a-color - 1 lb. (440g) Bags (P/N 255140)

*Special Orders: Most products are available in single colors or stock mixes. Additional time and/or charges may apply for custom orders or custom mixes.*

**Please check whether all the products you ordered are supplied.**

## **4. Description of the A/C AIR LAUNCHER™**

The user has the ability to produce a spectacular simulated fireworks display, outdoors, without the risk of fire! When loaded properly, this device will safely propel tissue streamers and/or tissue (not paper) confetti to distances of up to 100' in the air! The end result resembles a cascading display of daytime firework-like effects. Note: due to wind resistance and low weight, confetti will not travel as far as streamers. The included 5-gallon air tank must be filled from an air compressor or be connected into a constant replenishing CO<sub>2</sub> air cylinder tank (available from your local gas supplier), eliminating the need for manual refills. The CO<sub>2</sub> air tank makes it economically feasible to do continuous reloads and refills for places like circuses or theme parks. Features a built-in safety release, two types of filling valves, a pressure gauge and an electric release solenoid valve (1/2" high-volume type). The launcher fires as soon as it is plugged in, or if connected to an electrical switchbox, as soon as it is switched on. Launcher comes with a 24VAC solenoid valve and 120VAC/24V transformer.

## **5. Safety instructions**

**WARNING: Read and understand all labels and operating instructions before attempting installation.**

- Inspect all equipment and barrel before use. Do not use if barrel is cracked or chipped.
- Be sure area around launcher is dry before applying electrical power.

- Never point the muzzle directly at anyone or look over the barrel when pressurized and loaded.
- Secure the launcher so that it will not be moved after it is aimed.
- Use a safety cable if the launcher is rigged above ground.
- When using, keep away from spectators and always aim straight up over everyone's head
- **WARNING!** Never use a confetti-launching product if there are open flames present.
- Use only tissue-type confetti or streamers that are flame retardant as sold by CITC.
- Never use paper dots or heavy paper confetti.
- **Pressurize up to maximum 100 PSI (6.9 bar) only!**

## 6. Operating the A/C AIR LAUNCHER™

### 6.1 Assembly

- Secure a good location for the machine to rest solidly on the floor.
- Secure the launcher so it will not be moved after it is aimed
- Anchor as needed with straps, screws, or sandbags.
- Use a safety cable if the launcher is rigged above ground
- Install the 2" (5cm) barrel on the valve assembly.

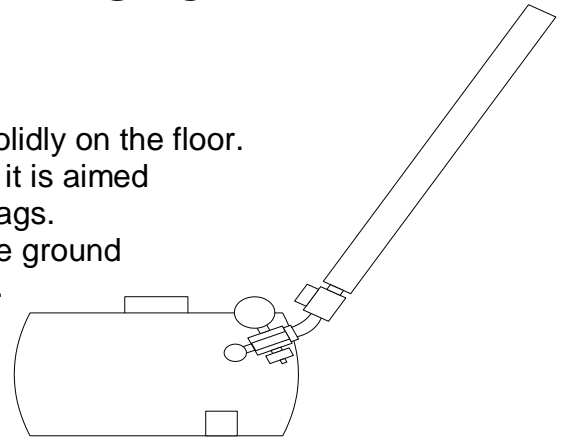

### 6.2 Loading

- If you power the transformer, the solenoid immediately releases the air. Always be sure your power is off before loading and pressurizing. As soon as you plug it in, it will fire.
- It is a good practice to test the solenoid valve with a charge of air before loading the barrel.
- Optional lifting cup: for 2" (5cm) barrel loading style, insert a foam plug (lifting cup) by pushing the entire foam disk down the barrel to the bottom. You may need to squeeze the bottom of the disk to make it fit. If lifting cups are unavailable, use paper wadding. The lifting cup acts as a bottom expanding sealer, making the device more powerful. This ejects your streamers for a longer distance. Now you are ready to load product on top of the lifting cup. Hard press, packing is not necessary.
- Indoors: We recommend a minimum of 60 rolls of 30' streamers. The more you include, the more spectacular the effect! If your budget allows, using 120 rolls looks great. If you want an unbelievable effect, use 240 rolls! You may fill the unit to the top if you wish or just load it to ½ full.
- Outdoors or large arenas: the bigger and heavier streamers will travel further. For the highest altitude and the best visual effect, load at least 36 of the 30' streamers. Warning: sudden cross gusts of wind and trees can be your enemy! We have found the best visual effects when each device is loaded with the same style or type of product.

### 6.3 Optional backpressure cap

- A backpressure cap can also be installed over the end of the barrel to improve performance. If the distance isn't far, a backpressure cap is not needed. For smaller loads, backpressure caps may be needed for added backpressure. If firing on low pressure, the 2" (5cm) cap needs 1 – ½ rounds of black tape around the end of the barrel. This causes a pop and develops backpressure for further launch.
- Installing the cap: Slip the cap over and snug it down. With masking tape, neatly tape 1 ½ turns around the side of the barrel and cap. After taping, roll your hand around the tape pressing down to form an airtight seal. This will cause the backpressure to increase when fired and blow the lid off, expelling the contents under greater pressure. Do not tape over the top of the cap.
- Note: the lifting cups are sometimes reusable if you can find them, however the backpressure caps may need replacing if they tear when blown off.

#### 6.4 Pressurizing the tank

- Fill tank from your own air source. Use an air compressor capable of up to 100 PSI, a tank of compressed air, or even a tire pump. For the most refills of air, use CO<sub>2</sub> with a regulator. Pressurize at 80 – 100 PSI (5.5 – 6.9 bar) only! The CO<sub>2</sub> tank should only be turned on when it is time to fire the launcher. You could, in a jam, pressurize the tank with a tire pump with a tire air fitting. See the valve illustration below.

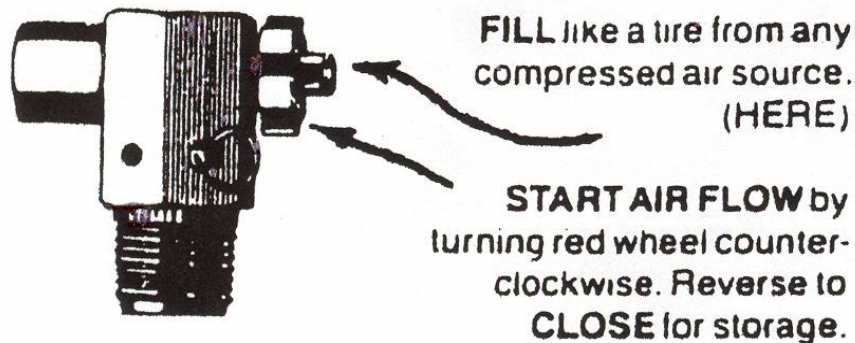

#### 6.5 Firing the A/C Air Launcher™

**Do not plug into power until finished reading these instructions.** This unit is equipped with a 120VAC/24VAC transformer (P/N 704100) (or 230VAC/24VAC P/N TBA) to actuate the solenoid and this will release the air pressure. Plug the transformer into a 120VAC outlet that is controlled with an off/on switch. The solenoid valve opens if there is power to the transformer, so always have the switch “off” until ready to shoot the product into the air.

Use of a momentary switch is recommended to help save pressure for the next shot. If you use a regular switch or simply plug it into the wall, you'll release all of the pressure in the tank. (With a momentary, it is possible to get two shots out of the air tank before refilling).

## 6.6 Troubleshooting

1. **If you plug in the transformer, the solenoid immediately releases the air.** Always be sure your power is off before loading and pressurizing. As soon as you plug it in, it will fire.
2. **Air is leaking and won't hold pressure:** Check all connections with soap and water and tighten as necessary.
3. **Even at 100 PSI (6.9 bar) pressure, the confetti doesn't launch.** You have packed it too tight. Do not pack tightly. Only the push cup should be shoved to the bottom. Add confetti or streamers with a light pack. Never use paper dots. Always use fire retardant lightweight tissue-type confetti or streamers.

## 7. Service and Maintenance

### **Care of your A/C AIR LAUNCHER™ will give you years of service**

- It is a good practice to test the solenoid valve with a charge of air before loading the barrel.
- When finished with use:
  - Remove and inspect barrel for cracks
  - Check that cord is in good condition, not pinched or broken.



## 8. Technical Data

A/C Air Launcher™ Technical Data P/N 101050 (230VAC P/N 101051)	
Dimensions	Assembled: 35" x 34" x 14" (89 cm x 86 cm x 36 cm)
Weight	20 lb (9 kg)
Shipping Weight	33 lb (15 kg)
Shipping Box Size	24" x 18" x 18" (61 cm x 46 cm x 46 cm)
Distance	Streamers: 100 ft (30.5m) Confetti: 50 – 60 ft (15m – 18m)
Barrel	2" x 24" (5 cm x 60 cm)
Solenoid Valve	¾" (1.9cm), 24 VAC/0.7 A with 120VAC (or 230VAC) Transformer
Air fittings	Quick-Disconnect, tire valve, pressure relief, pressure gauge
Working pressure	80 -100 PSI (5.5 - 6.9 bar)
Actuation	Power on (or optional switch)
DMX	Optional Universal DMX
Electrical Supply	120 VAC, 0.2 A, 60 Hz (or 230 VAC, 0.1 A, 50 Hz)
Limited Warranty	One year

Rev: 4/02/04

## 9. Limited Warranty Conditions for the A/C AIR LAUNCHER™

- 1. Subject to the following conditions we will repair any defect or fault in the unit if it is caused by a proven factory fault and has been advised immediately after appearance and within 30 days of delivery to the end user. Insignificant deviations of the regular product quality does not guarantee replacement rights, nor do faults or defects caused by water, by generally abnormal environment conditions or Force Majeure.**
- 2. Limited Warranty Service will be done in the following way: Faulty parts will be repaired or replaced (our choice) with correct parts. Faulty units have to be shipped to us or sent to us at customer's expense. The RMA# has to come with the faulty unit.**
- 3. The customer loses all rights for limited warranty services, if any repairs or adjustments are done to the units by unauthorized persons and/or if spare parts are used, which are not approved by us. Also non-compliance with the instructions in this manual or mistakes by incorrect handling/treating of the machine, any faults and damages caused by undue force will lead to a loss of limited warranty.**
- 4. Freight costs to CITC when under the limited warranty services are the responsibility of the customer. CITC will pay freight upon return.**
- 5. Limited warranty services do not cause an extension of the limited warranty time or the start of a new limited warranty time. The warranty of replaced parts ends with the limited warranty time of the whole unit.**
- 6. If a defect/fault can not be repaired by us in a satisfactory time, we will, within 30 days after sale of the unit, our choice either:**
  - Replace the whole unit for free or**
  - Refund the lesser value or**
  - Take back the whole unit and refund the purchase price, but not more than the usual market price at the time of refund.**
- 7. Further claims, especially for damages, losses etc. outside the unit are excluded.**
- 8. Your limited warranty coverage is based on completion of the warranty card and returning it with your proof of purchase within 30 days of purchase.**

**Your limited warranty coverage is based on completion of the warranty card and returning it with your proof of**

**purchase within 30 days of purchase. If you should send the unit for service, obtain your RMA # by calling CITC. Payment arrangements for repair must be made before receiving RMA # in case unit is not covered under Limited Warranty.**

**Send unit to:**

**CITC  
RMA # XXXXXXX  
1420 80<sup>TH</sup> ST. SW #D  
EVERETT, WA 9803  
Tel: (888) 786-CITC or (425) 776-4950  
Fax: (425) 776-5129  
Website: [www.citcfx.com](http://www.citcfx.com)  
E-mail: [info@citcfx.com](mailto:info@citcfx.com)**



1420 80<sup>TH</sup> ST. SW., EVERETT, WA 98036-7083  
425-776-4950 ✧ FAX: 425-776-5129  
[www.citcfx.com](http://www.citcfx.com) ✧ [info@citcfx.com](mailto:info@citcfx.com)

September 22, 2009