

This data sheet covers D60 Studio fixtures as shown. See other datasheets for other versions.

GENERAL INFORMATION

ETC's Desire D60 Studio lighting fixture uses the newest technology in high-output white light LEDs to create an ideal luminaire for video, film and other 'white light only' applications. Three different LED options give the user a choice for just the right white light output for the job. The D60 Studio offers a rugged die-cast enclosure, quiet, fan-cooled operation, multiple lens options and advanced user interface. The User Interface enables easy configuration and specific features for video and film professionals. The fixture can be configured to operate under console control for studio systems or in stand-alone 'no console required' settings for location lighting.

D60 Studio LED Options

D60 Studio fixtures offer three different LED array choices based on specific white light functions. The D60 Studio fixture is available with any one of the following arrays (not interchangeable) to best suit the intended application.

- D60 Studio HD™ – Studio HD combines warm white and cool white LEDs for variable color temperature mixing. Added to this are five carefully chosen LED colors from the Selador® x7 Color System™ to fill in the white LED spectral gaps. D60 Studio HD provides the richest variable white light possible in an LED fixture
- D60 Studio Daylight™ – Studio Daylight contains sixty 5600K LEDs for high-intensity, non-variable cool white output
- D60 Studio Tungsten™ – Studio Tungsten contains sixty 3000K LEDs for high-intensity, non-variable warm-white output

ORDERING INFORMATION

D60 Studio

MODEL	DESCRIPTION
SELD60HI	D60 Studio HD wash fixture – for highest-intensity variable white light output with broad spectrum richness and color rendering
SELD60DI	D60 Studio Daylight wash fixture – sixty 5600K emitters for single color, non-adjustable daylight output
SELD60TI	D60 Studio Tungsten wash fixture – sixty 3000K emitters for single color, non-adjustable tungsten-like output

Note: D60 Studio luminaires ship with hanging yoke, 25° secondary lens and input lead with connector of choice. See page 2 for connector options. C-clamps are not included.

SELD60 H I – 0X

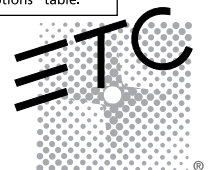
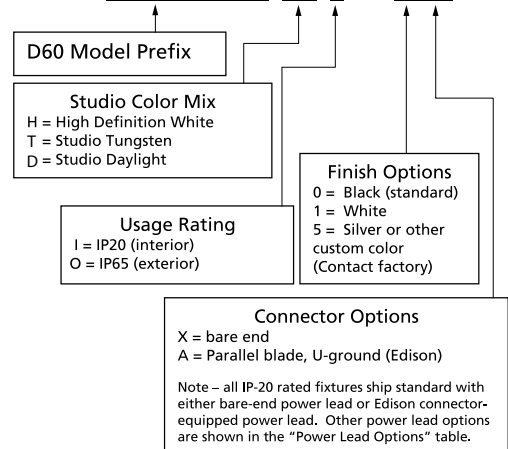

SPECIFICATIONS

GENERAL

- 60 LED variable white light wash fixture
- ETL listed to UL1573 – the standard for stage and studio lighting units
- IP20-rated for indoor use
- Power and DMX in/thru connections for easy setup
- User-friendly control interface with multiple modes and fixture settings

PHYSICAL

- Rugged die-cast all-metal housing
- Easy access slots for secondary lenses and accessories
- Uses 8-7/8"/225mm lenses and accessories
- Available in black (standard), white or silver (optional) or custom colors (contact factory)
- Hanging yoke standard. Optional yoke/floor stand available

ELECTRICAL

- 100VAC to 240VAC 50/60 Hz universal power input
- Neutrik power in and thru connections
- Up to 9 fixtures (15A max) may be linked via power thru connector
- Requires power from a non-dim source

LED*

- 50,000 hour LED life (50,000 hours to 70% intensity)
- 60 Luxeon® Rebel 2.5W LED emitters
- Studio Daylight and Studio Tungsten use Rebel ES white light emitters for higher output

* See additional LED notes on page three

COLOR

- Studio HD™ array use warm and cool white light emitters with additional deep color emitters
- Studio HD produces variable white light with broad spectrum richness
- Studio HD beautifully illuminates skin tones and other objects for natural appearance and high color rendering
- Studio Tungsten™ and Studio Daylight™ provide good color rendering at very high brightness

OPTICAL

- Primary field angle of 17°
- Secondary lenses available for multiple beam spread options
- Fixtures ship with a 25° lens; additional lenses must be ordered separately
- Refer to accessories for lenses available

CONTROL

- DMX512 in and thru via five-pin XLR connectors
- Multiple control options including strobe and console-free Master/Slave mode
- See DMX Control Table for additional information
- 15-bit virtual dimming engine provides smooth, high quality theatrical fades
- RDM functionality for address and setting changes.

THERMAL

- Ambient operating temperature of 4° to 104°F (-20° to 40°C)
- Active electronic thermal management for droop-free operation
- Low-noise fan cooling
- Fixture is designed for continuous operation up to 104°F (40°C) ambient temperature and requires free flow of air around fixture housing

ADDITIONAL ORDERING INFORMATION

Power Input Cables

Use information below to order 5' power input leads with factory fitted connectors

MODEL	DESCRIPTION
DPA-A	5' PowerCon™ to parallel blade U-ground (Edison) connector
DPA-B	5' PowerCon to 20A two pin and ground (stage pin) connector
DPA-C	5' PowerCon to grounded 20A twistlock connector
DPA-X	5' PowerCon to bare-end power input lead.

Power Thru Jumpers

Note: Power thru jumpers connect to fixture's output (thru) connector to provide link to successive fixtures

MODEL	DESCRIPTION
DPJ-5	5' PowerCon to PowerCon fixture to fixture jumper
DPJ-10	10' PowerCon to PowerCon fixture to fixture jumper

Fixtures Accessories

MODEL	DESCRIPTION
SLD60YUK	Yoke with floor stand attachment
490BD	Barn door (Use only as a flexible top hat to diminish aperture glare. Not for beam shaping)
490CF	Color Frame (use for round and oblong lenses)
490L	Egg Crate Louver
490TH3	Top Hat 3" Tube
490TH6	Top Hat 6" Tube
490PHH	Half Hat 6" Tube
400CC	C-Clamp (does not ship with fixture)
400SC	Safety Cable (32")
DPSJ-X	25' PowerCon to Edison input power cable with inline switch

ADDITIONAL ORDERING INFORMATION

Secondary Lens Option

MODEL	DESCRIPTION: The following lenses are cut for D60™ fixtures and create round, linear or oblong field patterns as described below. These lenses are not for use in Selador® classic (Vivid™, Lustr®, Paletta™, etc.) fixtures.	
Narrow Linear Field	Note: This is the same material as Selador Classic lenses	
SELL20-9	9" 20° lens (narrow linear field)	Linear lenses may be combined to create desired field size, i.e. 40° X 60°
SELL30-9	9" 30° lens (narrow linear field)	
SELL40-9	9" 40° lens (narrow linear field)	
SELL60-9	9" 60° lens (narrow linear field)	
SELL80-9	9" 80° lens (narrow linear field)	
Round Field		
SELR25-9	9" 25° lens (round field)	
SELR35-9	9" 35° lens (round field)	
SELR45-9	9" 45° lens (round field)	
SELR75-9	9" 75° lens (round field)	
Oblong Field		
SELO2040-9	9" 20° x 40° lens (oblong field)	
SELO3070-9	9" 30° x 70° lens (oblong field)	
SELO3580-9	9" 35° x 80° lens (oblong field)	

Typical Lens Field Profiles

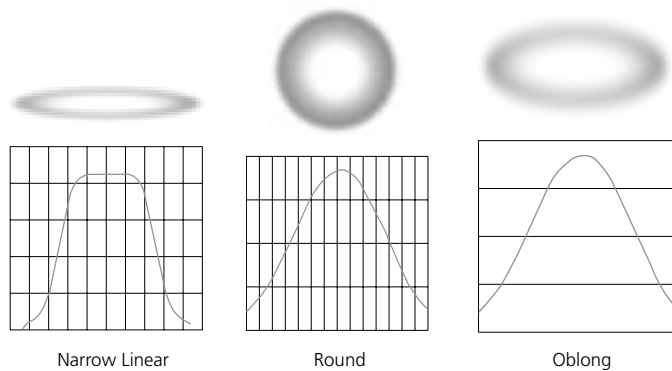

Power Consumption at Full Intensity

MODEL	VOLTAGE (V)	CURRENT (A)	WATTS
D60 Studio	120 / 240	1.35 / .68	161

NOTES ABOUT LED LUMINAIRES

All LED sources experience some lessening of light output and some color shift over time. LED output will vary with thermal conditions. Based on the LED manufacturer's B50 L70 specification, a Selador luminaire will achieve ~70% of its initial output after 50,000 hours of typical usage. In individual situations, LEDs will be used for different durations and at different levels. This can eventually lead to minor alterations in color performance, necessitating slight adjustment to presets, cues or programs.

CRI AND CQS RATINGS

Desire fixtures were evaluated for CRI and CQS performance using measured output spectrum and optimized mix solutions for a best spectral match to black body sources at 3200K and 5600K.

Fixture	CRI	CQS	Color Fidelity	Duv
D60 Vivid™ at 3200K	87	89	89	0.000
D60 Vivid at 5600K	90	92	92	0.000
D60 Lustr+™ at 3200K	86	88	88	0.000
D60 Lustr+ at 5600K	93	92	92	0.000
D60 Studio HD™ at 3200K	89	90	91	0.000
D60 Studio HD at 5600K	92	94	94	0.000
D60 Studio Daylight™ at 5600K	71	70	69	0.001
D60 Studio Tungsten™ at 3000K	86	86	86	0.001

All D60 Studio luminaire versions provide excellent color rendering to the eye, particularly at higher color temperature settings such as 5600K. In most cases the Duv is 0.000. A Duv rating of 0.000 indicates that the color mix used is exactly on the black body line, with no green or magenta tint.

Notes to Videographers:

- All Desire fixtures use Luxeon Rebel ES emitters specified by the strictest binning standards. However, on-camera LED response varies with different cameras and settings. Daylight LEDs can appear slightly greener than other 5600K sources on camera.
- Fixtures with non-variable single-color daylight arrays such as Studio Daylight may use standard color correction filters (Rosco 3314, Rosco 3316 or similar) to achieve the desired on-camera result.
- Camera tests using your specific set up are recommended to determine the best configuration.

CONTROL OPTIONS

Studio HD

User settings on D60 Studio fixtures allow multiple operational modes and settings for either console operation via DMX protocol or stand-alone operation. The expanded LCD display provides easy navigation to all possible settings and options. Some of the setting options are:

- Multiple DMX choices ranging from a simple RGB profile – which effectively controls all seven LED colors via three channels – to nine-channel direct color and intensity control
- Multiple dimming curve options
- Preset colors and effects for stand-alone (no console required) operation
- White point selection – white light and color behavior based on a specific color temperature white light, i.e. 3200K, 5600K, etc.
- Loss of data behavior options – instant off, hold last look for two minutes, etc.
- Output modes – three output options that offer the user a choice between maximum output and maximum consistency

See the User Manual for a complete explanation of all of the control settings and options for the D60 Studio.

Quick Set-Ups

To assist in managing the numerous control and fixture behavior choices, five combinations of operational settings are available to quickly get started. These settings are specifically created for different use situations and are easily accessible at the fixture display. Each setting can then be modified as required to take advantage of all of the possible control features.

Setting Title	Profile	Description	Typical Features*
Studio	Studio	Studio Factory Default: Enables three parameter control of white light (intensity, white point, and tint) via DMX from console or from fixture display – no console required	<ul style="list-style-type: none"> • Linear dimming curve • Regulated output for color consistency
General	Direct	For general purpose use including interior architectural applications	<ul style="list-style-type: none"> • Standard dimming curve • Regulated output for color consistency • 3200K white point setting
Stage	HSI Plus 7 Enabled	Theatrical lighting: Duplicates the color and dimming behavior of tungsten stage lighting fixtures.	<ul style="list-style-type: none"> • Incandescent dimming curve • Regulated output for color consistency • 3200K white point setting
XT Arch	HSI	Exterior Architectural lighting: Provides a high degree of color consistency in high ambient temperature environments.	<ul style="list-style-type: none"> • Standard dimming curve • Protected output • 3200 white point setting
High Impact	RGB	Event lighting: Enables quickest response, simple RGB control and strobe channel for maximum effect usage	<ul style="list-style-type: none"> • Quick dimming curve • Boost mode for maximum intensity • 5600K white point setting

*See user manual for complete list of features for each Quick Set-Up

CONTROL OPTIONS

Studio HD

DMX Input Channel Profiles

DMX Profile	DMX Channels	Channel Assignments	Notes
The Studio HD color array is designed for white light use. RGB, HSI, and HSIc profiles will operate as described but will produce a limited intensity and gamut of deep colors.			
Studio	6 (Ch. 4 not used)	1 – Intensity 2 – Color Point (CCT) 3 – Tint 4 – n/a 5 – Strobe 6 – Fan Control	Controls fixture as a white light unit. If no DMX, i.e. console input, is present, fixture can be adjusted for these three parameters on the UI at the back of the unit.
Direct	10	1 – Red 2 – Orange (white if Lustr+) 3 – Amber 4 – Green 5 – 3000K White 6 – 5700K White 7 – Indigo 8 – Intensity 9 – Strobe 10 – Fan Control	Direct control of each individual color with a separate master intensity channel. Color calibration of LEDs is not active in this mode. The ten-channel profile will produce the highest quality color cross-fades.
HSI	6	1 – Hue (coarse) 2 – Hue (fine) 3 – Saturation 4 – Intensity 5 – Strobe 6 – Fan Control	High resolution hue (two-channels), saturation, and intensity control. HSI mode will produce arbitrary color cross-fades around the color space.
HSIC	7	1 – Hue (coarse) 2 – Hue (fine) 3 – Saturation 4 – Intensity 5 – Strobe 6 – Fan Control 7 – Color Point (CCT)	High-resolution hue, saturation and intensity control as above, with the addition of a color point channel to adjust the color temperature of the fixture in both white light and color. Color cross-fade performance is the same as HSI.
RGB	6 (Ch. 4 not used)	1 – Red 2 – Green 3 – Blue 4 – n/a 5 – Strobe 6 – Fan Control	Effectively addresses all seven colors via three channels of control. RGB profile will produce medium quality color cross-fades

Additional profile options

Plus 7	Seven additional color control channels are available in RGB, HSI, and HSIc, and Studio profile settings. For example HSI with 'Plus 7' enabled becomes a 15-channel profile:	1 – Hue (coarse) 2 – Hue (fine) 3 – Saturation 4 – Intensity 5 – Strobe 6 – Fan Control 7 – n/a 8 – Plus Seven Control (on/off) 9 – Red 10 – Orange (white if Lustr+) 11 – Amber 12 – Green 13 – Cyan 14 – Blue 15 – Indigo	The desired color and intensity is achieved by using the HSI or RGB channels Placing channel 7 at a value over 51% gives the fixture a 15-channel profile. Channels 9-15 represent the native colors of the fixture and allow the operator to adjust individual color channels to fine tune the color output.
Strobe	Variable strobe control: 0% is no strobe. The fixture output will strobe more rapidly as the strobe channel value approaches 100%.		

CONTROL OPTIONS

Studio Daylight and Studio Tungsten (only)

Quick Set-Ups

Setting Title	Profile	Description	Typical Features
Studio	Studio	Enables control of intensity from luminaire UI; no console required	<ul style="list-style-type: none"> • Linear dimming curve • Regulated output for intensity stability
Single Channel	Direct	For general purpose architectural use	<ul style="list-style-type: none"> • Standard dimming curve • Regulated output for color consistency
Stage	Direct	Matches conventional luminaire performance	<ul style="list-style-type: none"> • Incandescent dimming curve • Regulated output

DMX Input Channel Profiles

DMX Profile	DMX Channels	Channel Assignments	Notes
Studio	3	1 – Intensity 2 – Strobe 3 – Fan Control (D60 only)	Control of parameters is also enabled from the luminaire's user interface. No console required.
Direct	3	1 – Intensity 2 – Strobe 3 – Fan Control (D60 only)	

PHOTOMETRICS

D60 Studio HD™

Mode	Degree	Candela	Field Lumens	Beam Lumens	Lumens Per Watt
Boost - Cold	16°	198,209	4,532	1,916	33.4
Regulated	16°	185,414	4,224	1,780	33.7

Metric Conversions: For Meters multiply feet by .3048
For Lux multiply footcandles by 10.76

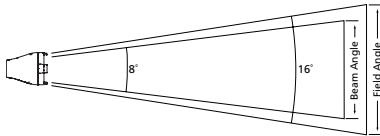

Throw Distance (d)	10.0' 3.0m	15.0' 4.6m	20.0' 6.1m	25.0' 7.6m	471.4 143.7
Field Diameter	2.8' 0.9m	4.2' 1.3m	5.6' 1.7m	7.0' 2.1m	-
Illuminance (fc)	2,222	988	556	356	1
Illuminance (lux)	23,917	10,630	5,979	3,827	10.76

For Field diameter at any distance, multiply distance by .281.
For Beam diameter at any distance, multiply distance by .142.

Cosine Candela Plot

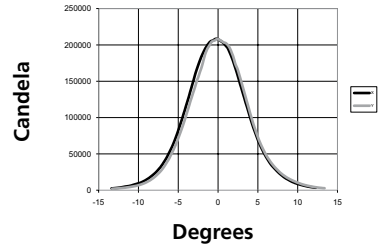

Iso-Illuminance Diagram (Flat Surface Distribution)

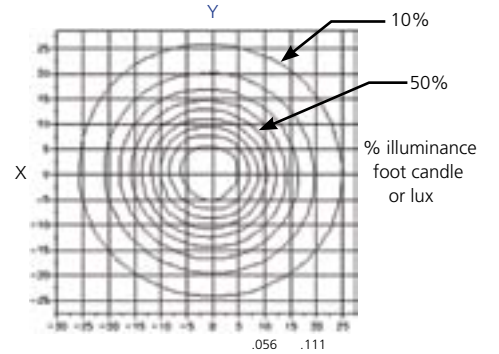

D60 Studio Daylight™

Mode	Degree	Candela	Field Lumens	Beam Lumens	Lumens Per Watt
Boost - Cold	22°	209,556	8,216	4,068	55.3
Regulated	22°	193,045	7,610	3,860	54.8

Metric Conversions: For Meters multiply feet by .3048
For Lux multiply footcandles by 10.76

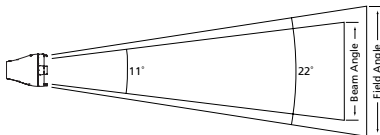

Throw Distance (d)	10' 3m	15.0' 4.6m	20.0' 6.1m	25.0' 7.6m	435.3' 132.7m
Field Diameter	39.1' 1.2m	5.8' 1.8m	7.7' 2.4m	9.7' 2.9m	-
Illuminance (fc)	1,895	842	474	303	1
Illuminance (lux)	20,398	9,066	5,099	3,264	10.76

For Field diameter at any distance, multiply distance by .387.
For Beam diameter at any distance, multiply distance by .194.

Cosine Candela Plot

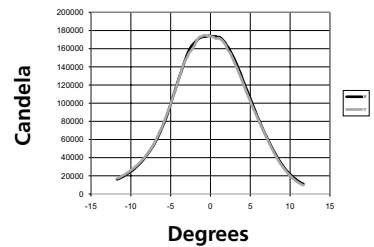

Iso-Illuminance Diagram (Flat Surface Distribution)

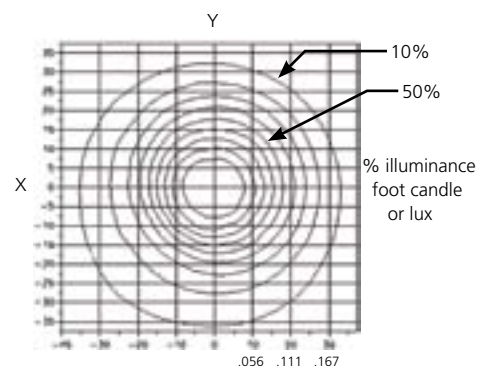

PHOTOMETRICS

D60 Studio Tungsten™

Mode	Degree	Candela	Field Lumens	Beam Lumens	Lumens Per Watt
Boost - Cold	23°	171,089	6,482	3,001	43.2
Regulated	23°	162,409	6,172	2,918	39.6

Metric Conversions: For Meters multiply feet by .3048
 For Lux multiply footcandles by 10.76

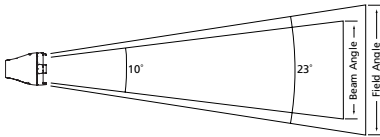

Throw Distance (d)	10.0' 3.0m	15.0' 4.6m	20.0' 6.1m	25.0' 7.6m	373.6' 113.9m
Field Diameter	4.1' 1.3m	6.2' 1.9m	8.3' 2.5m	10.4' 3.2m	-
Illuminance (fc)	1,395	620	349	223	1
Illuminance (lux)	15,020	6,676	3,755	2,403	10.76

For Field diameter at any distance, multiply distance by .414.

For Beam diameter at any distance, multiply distance by .189.

*** Throw Distance Multiplier (TDM)

To determine the distance from the center of the beam (Origin) to a certain illuminance level at a particular distance, multiply the desired throw distance by the TDM desired on the Iso-Illuminance diagram.

Throw Distance (TD) x Throw Distance Multiplier (TDM) = Distance from the Origin (DfO) (distance from the center of the beam)

Example: 25 feet (TD) x 0.047 (TDM) = 1.175 feet from center of beam (DfO)

For illumination with any lamp, multiply the candlepower of a beam spread by the multiplying factor (mf) shown for that lamp.

To determine illumination in footcandles or lux at any throw distance, divide candlepower by distance squared.

Cosine Candela Plot

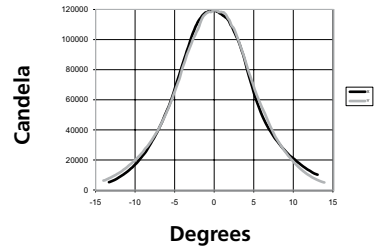

Iso-Illuminance Diagram (Flat Surface Distribution)

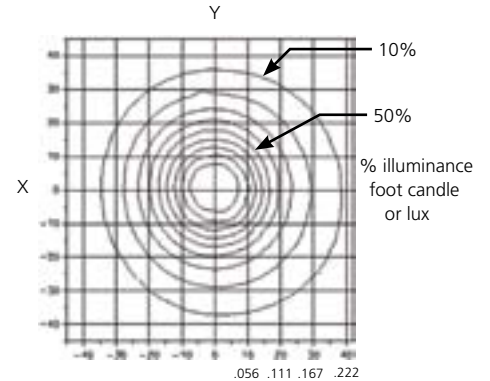

D60 ACOUSTICAL INFORMATION

FIXTURE	SPEED	SOUND PRESSURE LEVEL*
(Background noise level in test chamber)	N/A	18.3 dBA
Selador Classic	Single fan speed	28.1 dBA
Desire D60	30%	25.0 dBA
	51%	37.4 dBA
	60%	38.6 dBA
	100%	43.1 dBA

* Average of readings from 4 sides of fixture

The fan in all D60 fixtures is thermostatically controlled to run as needed.

- In regulated mode, fan speed in color-mixing fixtures (Vivid™, Lustr+™, etc.) will typically not rise above 30% when at full intensity in normal room temperature.
- 60% fan speed may be noted in Studio Daylight™ and Studio Tungsten™ fixtures at high intensities at room temperature.

PHYSICAL

Selador D60 Studio Weights and Dimensions

WEIGHT*		SHIPPING WEIGHT	
lbs	kgs	lbs	kgs
19.1	8.7	21.5	9.7

* Does not include mounting hardware

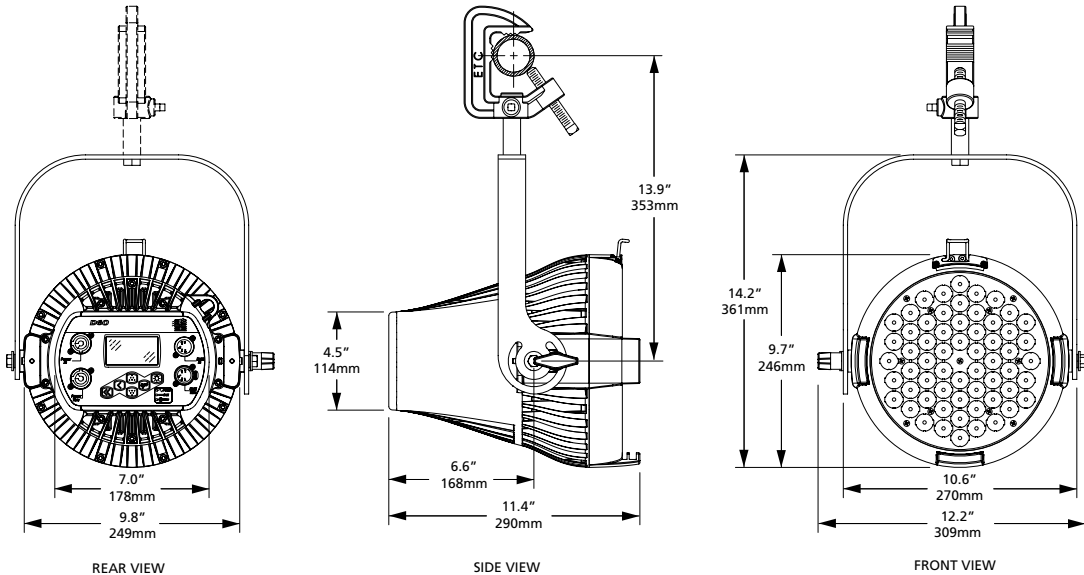

Corporate Headquarters • 3031 Pleasant View Rd, PO Box 620979, Middleton WI 53562 0979 USA • Tel +1 608 831 4116 • Fax +1 608 836 1736
 London, UK • Unit 26-28, Victoria Industrial Estate, Victoria Road, London W3 6UU, UK • Tel +44 (0)20 8896 1000 • Fax +44 (0)20 8896 2000
 Rome, IT • Via Pieve Torina, 48, 00156 Rome, Italy • Tel +39 (06) 32 111 683 • Fax +44 (0)20 8752 8486
 Holzkirchen, DE • Ohmstrasse 3, 83607 Holzkirchen, Germany • Tel +49 (80 24) 47 00-0 • Fax +49 (80 24) 47 00-3 00
 Hong Kong • Room 1801, 18/F, Tower 1 Phase 1, Enterprise Square, 9 Sheung Yuet Road, Kowloon Bay, Kowloon, Hong Kong • Tel +852 2799 1220 • Fax +852 2799 9325
 Web • www.etcconnect.com • Copyright©2013 ETC. All Rights Reserved. All product information and specifications subject to change. 7410L1007 Rev. H USA 01/13

This product is protected by one or more of the following U.S. Patents: 6,016,038, 6,150,774, 6,788,011, 6,806,659, 6,683,423 and 7,023,543